

INGERSOLL RAND H5UL



Specifications

Model	H5UL
Power type	Air
Brake type	Manual ext. band brake
Weight	271 kg (No cable)
Line pull (Nominal capacity)	1361 kg
Line speed	46 m/min
Drum root diameter	175 mm (7")
Wire rope diameter	9.5 mm (3/8"), 11 mm (7/16"), 13 mm (1/2")
Rope anchor hole diameter	17.5 mm (11/16")
Motor	14 hp
Avg. CFM required	290
Full drum capacity	440 m (9.5mm wire rope) 308 m (11mm wire rope) 248 m (13mm wire rope)
Drum length	402 mm (15 13/16")
Max stall pull (First layer @6.3 bar)	3538 kg

Recommended working length is 80% rope capacity

Dimensions

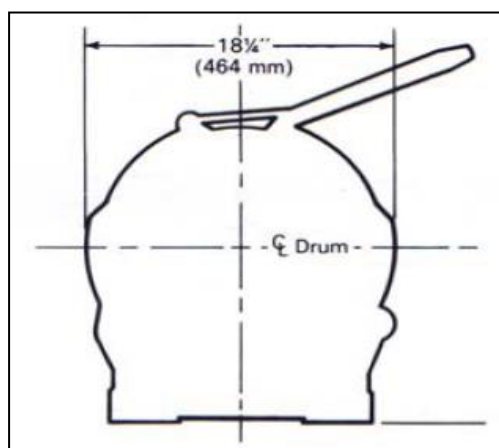
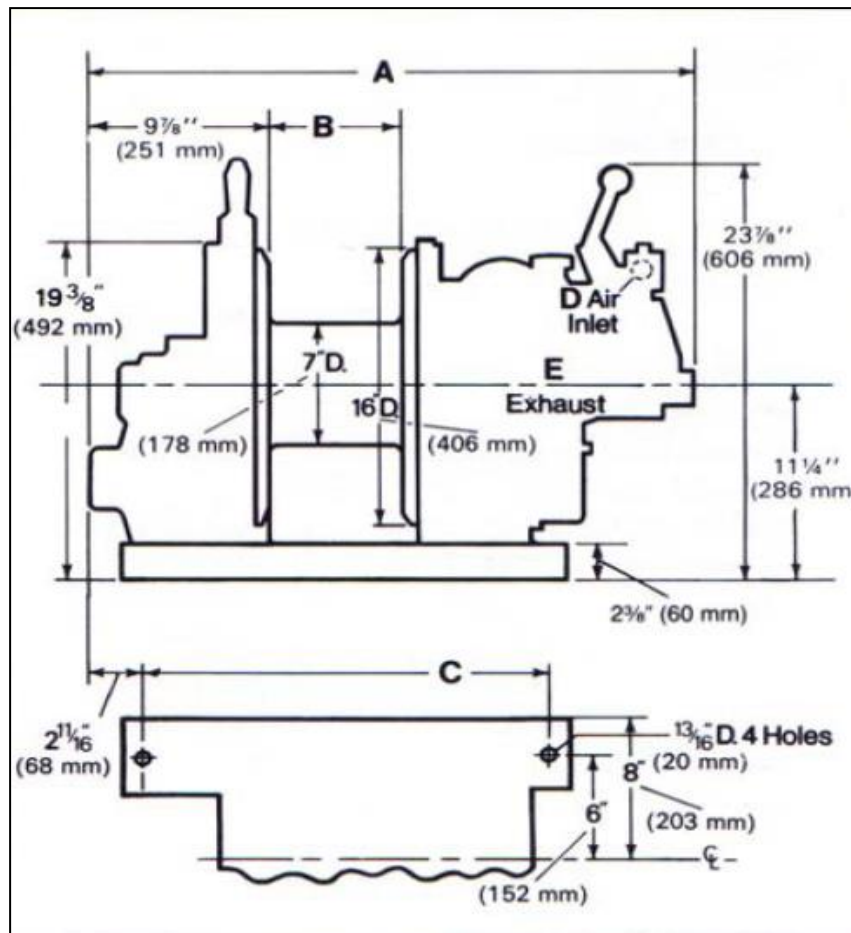

- A - 1040 mm (40 15/16")
- B - 402 mm (15 13/16")
- C - 772 mm (30 3/8")
- D - 31 mm (1.25" NPT)



AmoraSub

www.amorasub.pt

Parque Industrial S. Marta
de Corroios
Rua Manuel Ribeiro, Lote 13
2845-409 Amora - Portugal

T +351 919 708 279
E geral@amorasub.pt