

## INGERSOLL RAND 25UWB1142

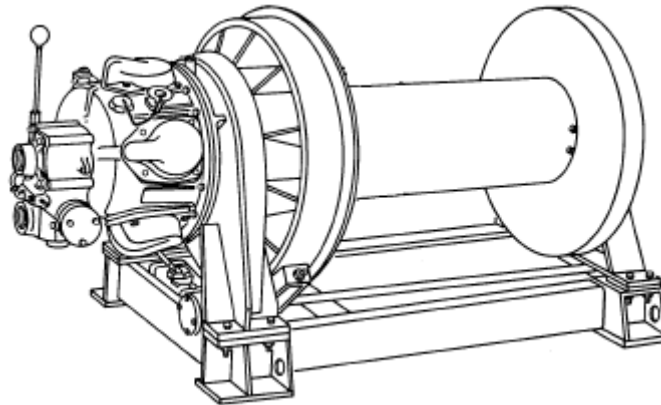

### Specifications

Model	25UWB1142
Power type	Air
Brake type	Auto band brake
Weight	974 kg (No cable)
Line pull (Nominal capacity)	6123 kg
Line speed	17 m/min
Wire rope diameter	19 mm (3/4"), 22mm (7/8")
Full drum capacity	737 m (19mm wire rope) 504 m (22mm wire rope)
Drum dimensions (D x F x L)	324 x 762 x 762 mm
Shipping dimensions (L x W x H)	1876 x 966 x 978 mm

Recommended working length is 80% rope capacity



## AmoraSub

[www.amorasub.pt](http://www.amorasub.pt)

Parque Industrial S. Marta  
de Corroios  
Rua Manuel Ribeiro, Lote 13  
2845-409 Amora - Portugal

T +351 919 708 279  
E [geral@amorasub.pt](mailto:geral@amorasub.pt)