

HYDRA-TECH S4VHLDI

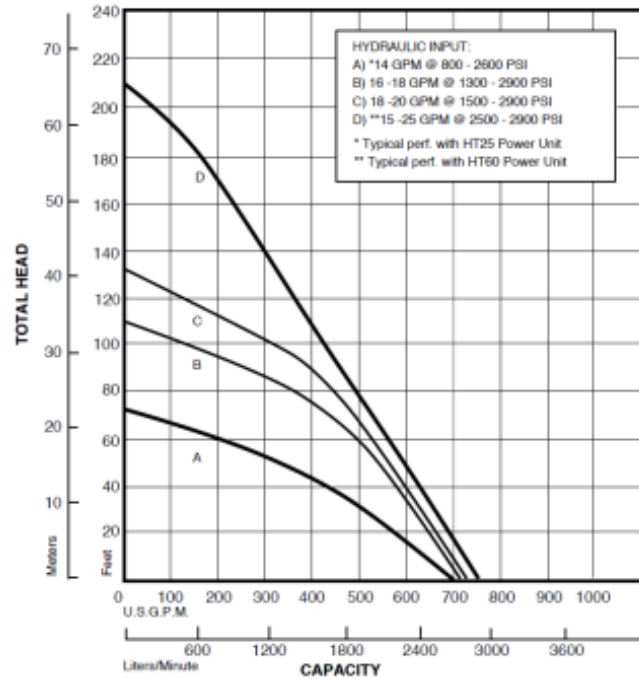

Pump Performance



Model	S4VHLDI (Ductile Iron)
Weight	134 kg
Height	84 cm
Width	50 cm
Discharge	100 mm (4"), NPT(F)
Inlet Flange	100 mm (4"), 125# ASA
Solids Handling	8 cm (3")
Hose Ports	25 mm (1"), (-16) SAE
Pump Body	Ductile Iron
Impeller	Stainless Steel



AmoraSub

www.amorasub.pt

Parque Industrial S. Marta
de Corroios
Rua Manuel Ribeiro, Lote 13
2845-409 Amora - Portugal

T +351 919 708 279
E geral@amorasub.pt

Dimensions

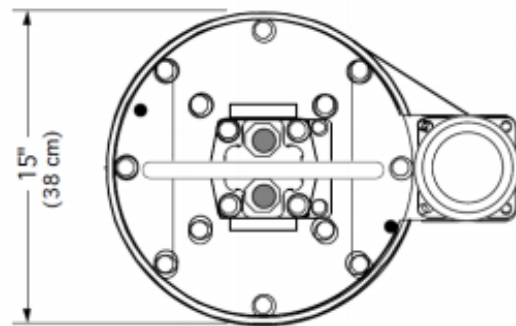
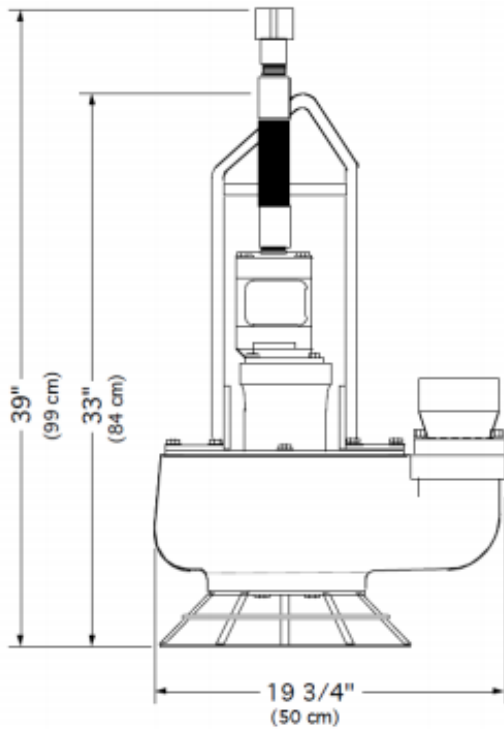

AmoraSub

www.amorasub.pt

Parque Industrial S. Marta
de Corroios
Rua Manuel Ribeiro, Lote 13
2845-409 Amora - Portugal

T +351 919 708 279
E geral@amorasub.pt