

HYDRA-TECH S3T

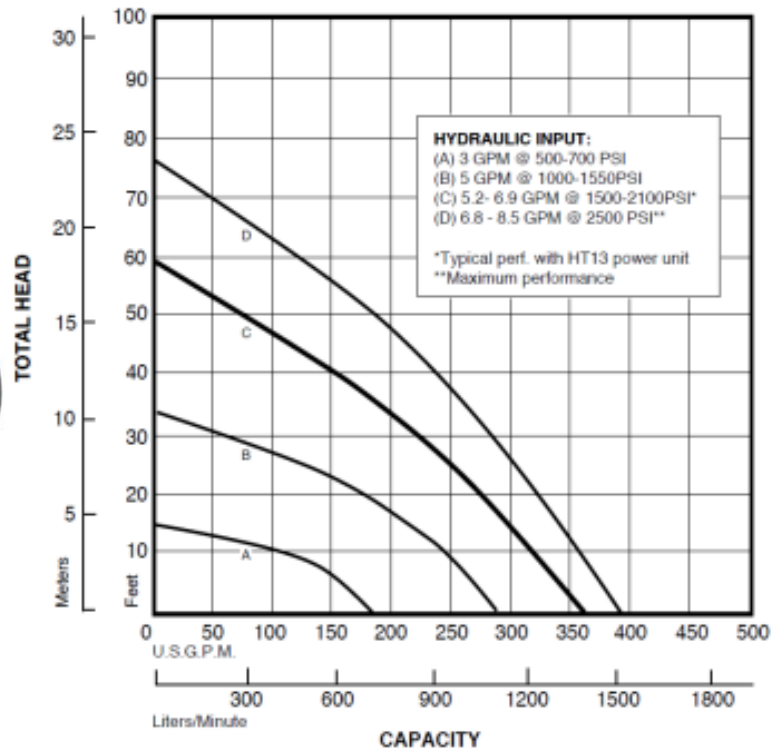

Pump Performance



Model	S3T (Aluminium)
Weight	11 kg
Height	36 cm
Width	30 cm
Discharge	75 mm (3"), NPT(F)
Inlet Flange	75 mm (3"), 125# ASA
Solids Handling	63 mm (2 1/2")
Hose Ports	1/2", NPT(F)
Pump Body	Aluminum
Impeller	Stainless Steel



AmoraSub

www.amorasub.pt

Parque Industrial S. Marta
 de Corroios
 Rua Manuel Ribeiro, Lote 13
 2845-409 Amora - Portugal

T +351 919 708 279
 E geral@amorasub.pt

FICHA TECNICA

Wear Ring	Ductile Iron
Shaft	Plated 4140 Steel
Shaft Seal	Carbon/Ceramic (Std)
Elastomers	Buna N (Std)
Hydraulic Oil	214-320 s.s.u. @ 64° C
Input Flow	Max 30 LPM
Operating Pressure	Max 170 bar
Power Source	Any Open Center Hydraulic System

Dimensions

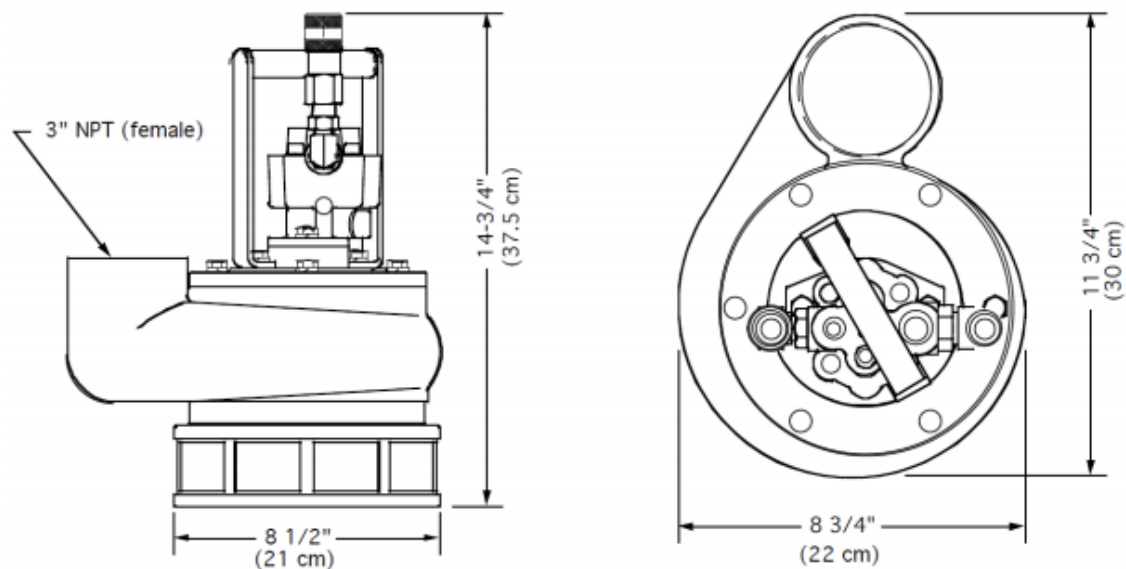

AmoraSub

www.amorasub.pt

Parque Industrial S. Marta
de Corroios
Rua Manuel Ribeiro, Lote 13
2845-409 Amora - Portugal

T +351 919 708 279
E geral@amorasub.pt