

## TOYO SUBMERSIBLE AGITATOR SAND PUMP

## FEATURE

- Standard models of Toyo Submersible Agitator Sand pump provides high durability and resistance for abrasion.
- Two Sealing method; oil seal/rareflon seal and mechanical seal are available.
- Suitable for dredger/dredging system. DPF provides best performance for dredging, wide range of specification fits to many kind of application.



## SPECIFICATION

MODEL	BORE (mm)	STANDARD		SOLID SIZE (mm)	OUTPUT (kW)	VOLTAGE (V)	POLE (P)	WEIGHT (kg)	CABTYRE CABLE 10m (symbol x mm <sup>2</sup> x core)
		HEAD (m)	CAPACITY (m <sup>3</sup> /min)						
DPF-15	100	15	1.5	35	11	200	6	490	3PNCT×14 <sup>f</sup> ×4C
DPF-15H *	100	17	1.5	35	11	200	6	490	3PNCT×14 <sup>f</sup> ×4C
DPF15B	150	8	3.2	60	11	200	6	530	3PNCT×14 <sup>f</sup> ×4C
DPF-20	100	20	1.5	35	15	200	6	550	3PNCT×14 <sup>f</sup> ×4C
DPF-20H-1	100	25	1.5	30	15	200	6	550	3PNCT×14 <sup>f</sup> ×4C
DPF20B	150	10	3.2	60	15	200	6	540	3PNCT×14 <sup>f</sup> ×4C
DPF-30	100	30	1.5	35	22	200	6	750	3PNCT×38 <sup>f</sup> ×3C-3.5 <sup>f</sup> ×1C
DPF-30B	150	15	3.2	60	22	200	6	730	3PNCT×38 <sup>f</sup> ×3C-3.5 <sup>f</sup> ×1C
DPF-30BH *	150	20	3.2	60	22	200	6	730	3PNCT×38 <sup>f</sup> ×3C-3.5 <sup>f</sup> ×1C
DPF-40 *	100	33	1.5	35	30	200	6	750	3PNCT×38 <sup>f</sup> ×3C-3.5 <sup>f</sup> ×1C
DPF-40B	200	15	6.0	40	30	200	6	750	3PNCT×38 <sup>f</sup> ×3C-3.5 <sup>f</sup> ×1C
DPF-50	150	25	3.2	60	37	200	6	950	3PNCT×50 <sup>f</sup> ×3C-8 <sup>f</sup> ×1C
DPF-50H *	150	28	3.2	40	37	200	6	1050	3PNCT×50 <sup>f</sup> ×3C-8 <sup>f</sup> ×1C
DPF-50H *	150	28	3.2	40	37	200	6	950	3PNCT×50 <sup>f</sup> ×3C-8 <sup>f</sup> ×1C
DPF-50B	200	15	6.0	60	37	200	6	970	3PNCT×50 <sup>f</sup> ×3C-8 <sup>f</sup> ×1C
DPF-50BL	250	5	12	120	37	200	6	1150	3PNCT×50 <sup>f</sup> ×3C-8 <sup>f</sup> ×1C
DPF-60B *	200	22	6.0	60	45	200	6	1000	3PNCT×50 <sup>f</sup> ×3C-8 <sup>f</sup> ×1C
DPF-75B *	200	22	6.0	40	55	400	6	1120	3PNCT×38 <sup>f</sup> ×3C-3.5 <sup>f</sup> ×1C
DPF-75B *	200	28	6.0	60	55	400	6	1020	3PNCT×38 <sup>f</sup> ×3C-3.5 <sup>f</sup> ×1C
DPF-75BH *	200	40	3.2	40	55	400	6	1120	3PNCT×38 <sup>f</sup> ×3C-3.5 <sup>f</sup> ×1C

- Specifications are changeable without notice. Please ask for Specification Sheet for the details.
- Standard voltage of DPF-75B/DPF-75BH are 400V.
- \* only 50Hz available.
- \* only 60Hz available.



AmoraSub

www.amorasub.pt

Parque Industrial S. Marta  
de Corroios  
Rua Manuel Ribeiro, Lote 13  
2845-409 Amora - Portugal

T +351 919 708 279  
E geral@amorasub.pt

## SIZE

Unit : mm

MODEL	A (HEIGHT)	B (WIDTH)	C (LWL)	D	E	F	G	H	I
DPF-15	1275	750	1100	380	445	500	100	240	298
DPF-15H *	1275	750	1100	380	445	500	100	240	298
DPF15B	1275	841	1100	380	445	560	150	255	333
DPF-20	1310	825	1100	380	515	495	100	280	313
DPF-20H-1	1310	825	1100	380	535	495	100	280	313
DPF20B	1310	841	1100	380	445	560	150	255	333
DPF-30	1390	910	1200	415	635	515	100	320	333
DPF-30B	1390	955	1200	415	510	580	150	310	363
DPF-30BH *	1390	955	1200	415	510	580	150	310	363
DPF-40 *	1390	910	1200	415	635	515	100	320	333
DPF-40B	1390	1010	1200	415	510	600	200	310	393
DPF-50	1575	1020	1350	460	560	635	150	340	383
DPF-50H *	1580	1094	1350	460	660	650	150	350	443
DPF-50H *	1575	1020	1350	460	560	635	150	340	383
DPF-50B	1575	1065	1350	460	560	655	200	340	413
DPF-50BL	1650	1350	1450	460	560	762.5	250	360	613
DPF-60B *	1615	1065	1400	460	560	655	200	340	413
DPF-75B *	1670	1145	1450	460	660	670	200	350	473
DPF-75B *	1665	1065	1450	460	560	655	200	340	413
DPF-75BH *	1670	1145	1450	460	660	670	200	350	473

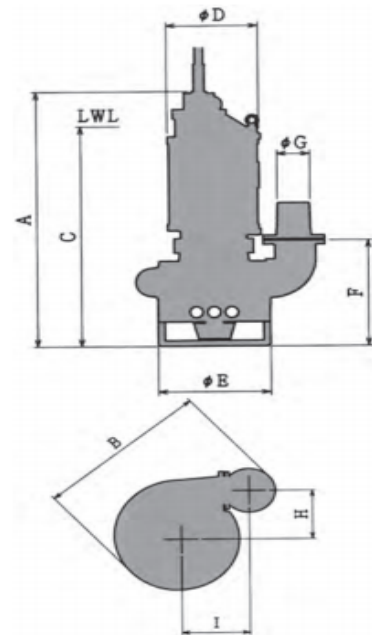

- Specifications are changeable without notice. Please ask for Specification Sheet for the details.
- \* only 50Hz available.
- \* only 60Hz available.

## PERFORMANCE CURVES

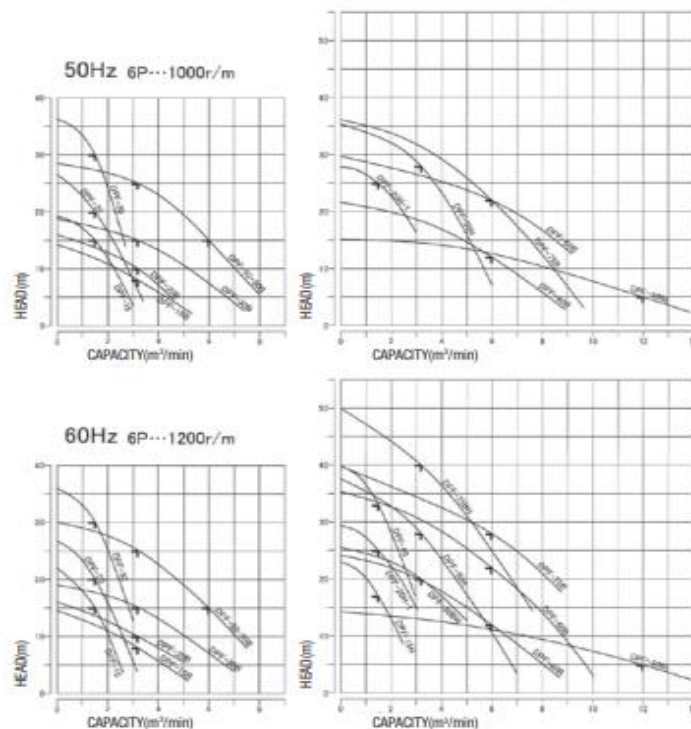

# AmoraSub

[www.amorasub.pt](http://www.amorasub.pt)

Parque Industrial S. Marta  
de Corroios  
Rua Manuel Ribeiro, Lote 13  
2845-409 Amora - Portugal

T +351 919 708 279  
E [geral@amorasub.pt](mailto:geral@amorasub.pt)