

HH150 - 150mm High Head Automatic Priming Pump

The SPP AUTOPRIME HH150 pump is designed for applications where a high lift is required. These will include mines and quarries and major works such as tunnels and deep foundations.

DESIGN FEATURES

- Skid mounted with integral fuel tank.
- 12 volt battery starting by key switch is standard.
- Pump will pass solids up to 45mm diameter.
- Reliable double mechanical seals which allow dry running. Optional spring assisted pressure seal.
- Pump can be left running when liquid is exhausted and will self prime when liquid is present.
- Rugged construction requires minimal operator maintenance.
- 25 cfm Vacuum Pump with coalescer and air exhaust to atmosphere
- Pump will run on load for 21 hours before refuelling



PUMP SPECIFICATIONS

Flow Rate	600 m ³ /h Maximum
Discharge Head	100 m Maximum
Working Pressure	10 bar Maximum
Hose Size	150mm (6 in.) Dia.
Max Solids Size	45 mm Diameter
Pump Speed Range	1200 rpm to 2200 rpm
Pump Casing	Cast Iron
Impeller	Cast Iron
Pump Shaft	Stainless Steel
Wear Plates	SG Iron
Suction Sump	Cast Iron

Shaft Seal	Silicon Carbide/Silicon Carbide
Elastomer	Viton
Diesel Engine	CAT C6.6 or Perkins 1106D
Starting	12 Volt Battery by Key Switch
Fuel Tank Capacity	300 litres
Full Load Consumption	17 litres per hour
Full Load Running Time	18 hours
Chassis Options	Sound Reducing Enclosure
Weight Dry	2200 Approx. kg

Specifications may be subject to change without notice.

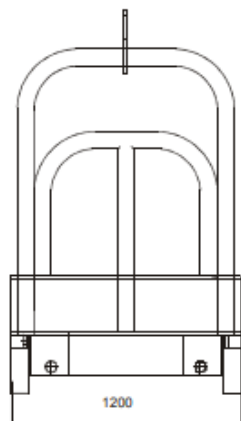

Pump, Engine & Priming System
Specifications may vary

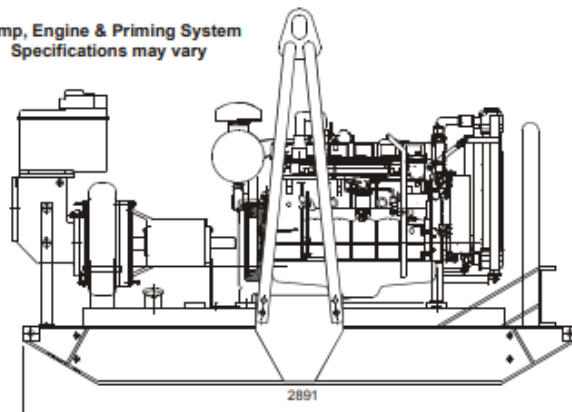

AmoraSub

www.amorasub.pt

Parque Industrial S. Marta
de Corroios
Rua Manuel Ribeiro, Lote 13
2845-409 Amora - Portugal

T +351 919 708 279
E geral@amorasub.pt

Pump Performance

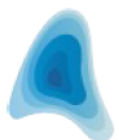
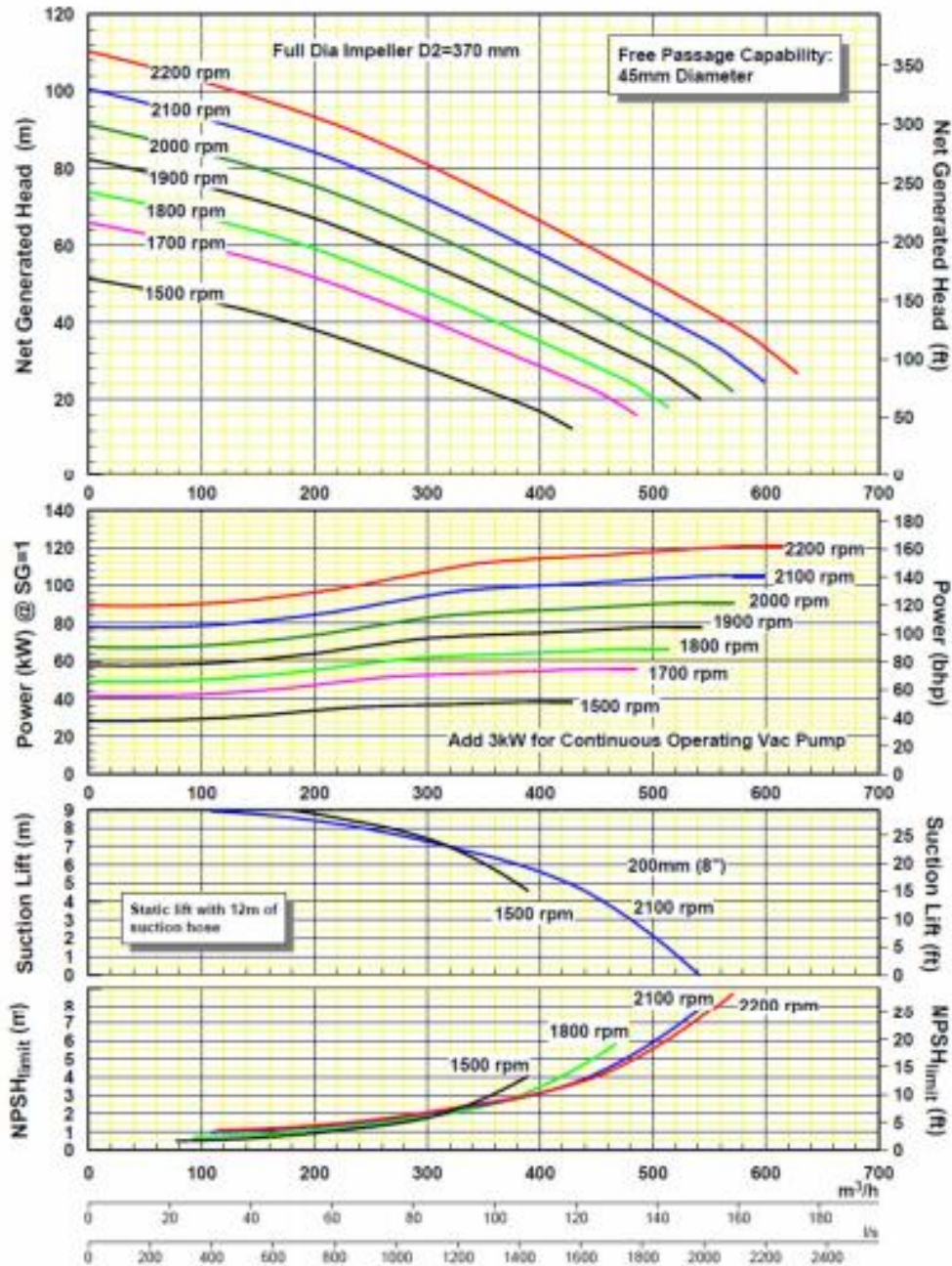

AmoraSub

www.amorasub.pt

Parque Industrial S. Marta de Corroios
 Rua Manuel Ribeiro, Lote 13
 2845-409 Amora - Portugal

T +351 919 708 279
 E geral@amorasub.pt