

# Hydraulic pump HY85

PUMP SPECIFICATIONS	Mod. A	Mod. B
Capacity [m <sup>3</sup> /h - (USGPM)]	240 - (1056)	360 - (1585)
Head [m - (ft)]	37 - (122)	33 - (109)
Impeller diameter [mm - (in)]/type	440 - (17.6)/3 blades closed	
Flanged bore size [DN.../PN... - (in)]	DN150/PN10 - (6)	DN200/PN10 - (8)
Cross section diameter [mm - (in)]	60 - (2.4)	
Weight [kg - (lbs)]	700 - (1540)	730 - (1606)

HYDRAULIC MOTOR	
Motor displacement [cc - (cu in)]	108 - (6.5)
Max. oil flow rate[l/min - (USGPM)]	130 - (34)
Max. pressure [bar - (psi)]	300 - (4350)
Power [kW-HP]	65-90
Speed [RPM]	1180

MATERIALS	
Casing	Spheroidal cast iron EN-GJS-500-7 (EN 1563)
Motor housing	Cast iron EN-GJL-250 (EN 1561)
Wear parts	High chrome EN-GJN-HV600 (XCr18) (EN 12513)
Main shaft	High tensile steel 39NiCrMo3 (AISI 9840)

SEALS / LUBRICANT	
Motor side seals	2 lip seals (BUNA)
Impeller side seals	5 lip seals (3 BUNA + 2 PTFE) + 1 V-RING (TPU)
Oil type	ISO 320

DIMENSIONS [mm - (in)]							
H	W	D	F	H1	A	B	C
1390	933	747	548	290	362	428	334
(55.6)	(37.3)	(29.9)	(21.9)	(11.6)	(14.5)	(17.1)	(13.4)

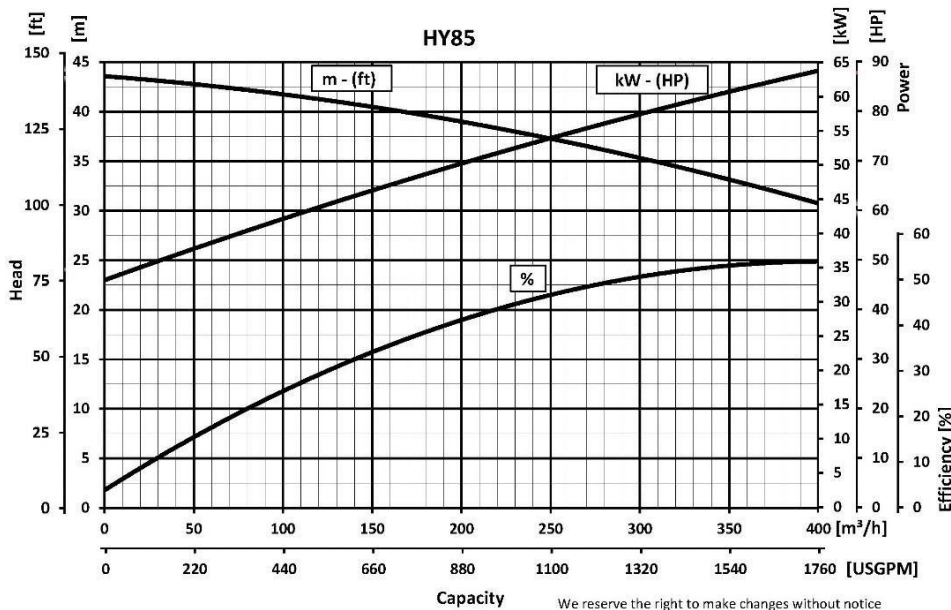
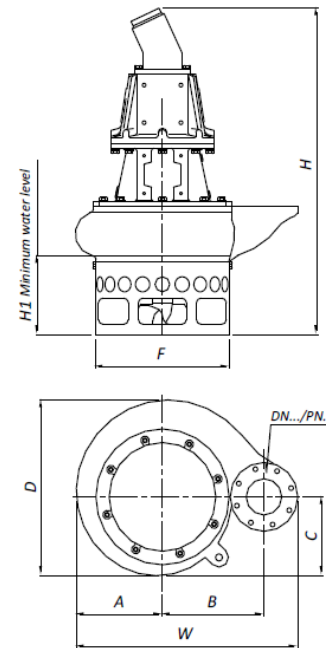

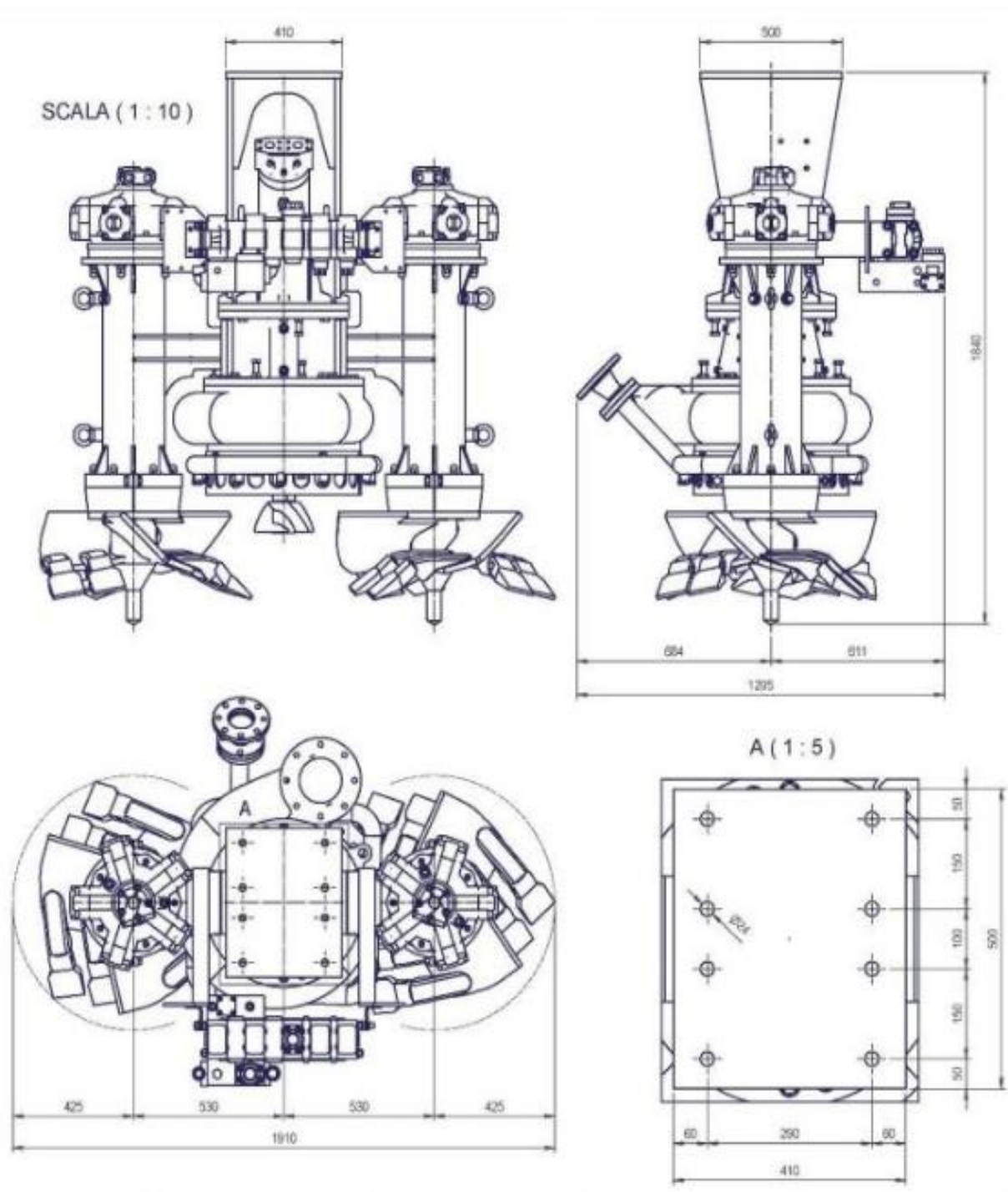

**AmoraSub**

[www.amorasub.pt](http://www.amorasub.pt)

Parque Industrial S. Marta  
de Corroios  
Rua Manuel Ribeiro, Lote 13  
2845-409 Amora - Portugal

T +351 919 708 279  
E geral@amorasub.pt